



Duo300 Electrical & Ignition Systems Diagnostic Procedures

Purpose:

You will learn to perform diagnostic procedures for the Duo300 electrical systems. You will use this instruction packet as a guide to complete this course.

Objective:

Given a boat, components, D.P.S. Analyzer, ohmmeter, tools, and materials, you will correctly perform diagnostic procedures to determine components to be within specification. You will be rated by your instructor for proper procedure, and the quiz at the end of this course.

Inventory:

- Boat
 - Components
 - Hand tool set
 - D.P.S. analyzer
 - OHM Meter
 - Hand towels
 - Safety glasses
-

Instructions:

Proceed to the work station and perform the test steps given in this instruction package. Record your test readings on the sheets as you perform the test. Compare each reading to the specification given. Complete the quiz at the end of this course.

Identify:

Electrical test procedures, system component functions, and use of test equipment.

Explain:

Test procedures, component specifications, and functions.



Duo300 Electrical & Ignition Systems Diagnostic Procedures

Electrical Test Procedures

Before you begin diagnostic procedures, be sure to verify the complaint. Many times electrical components are replaced when crossing in a wire or ground connection, or a weak battery could cause inaccurate readings.

Test procedures and specifications for the T-7 engine electrical systems will be performed using the Diagnostic Port System Analyzer (D.P.S.). The D.P.S. is a precision peak voltage reading tester that was designed to aid in diagnosing electrical systems for WetJet models. The following reflects performing tests at cranking speeds so that the engine will not run and can be tested. It is very important that a fully charged battery be used for this test. The test procedure using the D.P.S. Analyzer can also be performed on units that are in running condition, and also used for on the water testing. The D.P.S. Analyzer can perform the following tests:

- Charge coil output voltage
- Trigger (pulsar) coil output voltage
- C.D.I. output voltage
- Lighting coil (alternator) output voltage
- Tachometer (R.P.M.) reading
- Battery voltage

The D.P.S. Analyzer is equipped to make external connections to be used on other manufacturers units by using the external test jacks provided with the D.P.S. Analyzer, and the use of the manufacturers specifications. The external test jacks located on the front of the D.P.S. are as follows:

COLOR	POLARITY	PURPOSE
Red	Normal	Measuring systems with CURRENT readings
Green	Reverse	Measuring systems with OHM readings
Black	Ground	Common ground



Duo300 Electrical & Ignition Systems Diagnostic Procedures

Connecting the D.P.S. Analyzer Test Leads:

1. Make sure the engine is stopped when connecting tester leads.
2. Make sure the analyzer 'ON/OFF' toggle switch is in the 'OFF' position.
3. Remove the electrical box cover and locate the wire harness connectors with the proper color.
4. Insert test leads into connectors from the back side without disconnecting the wires. The engine must be stopped before making connections to protect the D.P.S. analyzer from damage.
5. To mount the D.P.S. to the boat, use the rubber straps provided. Mount the D.P.S. on the steering bar, connect the straps in a crisscross pattern from the front side of the handle bar pad.
6. Connect the engine stop lanyard when performing test.

If the engine cranks and will not start, and you have determined that the engine has no spark, make each of the following tests. Do not skip any test. Follow the procedures for each test given. Read the complete test procedure before performing any test. All tests are made with a known good battery.



Duo300 Electrical & Ignition Systems Diagnostic Procedures

D.P.S. Analyzer Tests to be Performed

A. Charge Coil Output Voltage Test

- 1) Remove the electrical box cover, locate the brown wire and the black wire. Use the D.P.S. red positive lead.
- 2) Connect the red test lead to the brown wire from the backside.
- 3) Connect the D.P.S. black lead to the black ground wire.
- 4) Turn the toggle switch to the 'ON' position.
- 5) Turn the dial selector to 'CHRG/EXT' position.
- 6) Install the lanyard and crank the engine. Record the reading _____ a.c. volts.
- 7) Compare to specification _____ a.c. volts.
- 8) Is it good _____ or bad _____?

B. Trigger (Pulsar) Coil Output Voltage Test

- 1) Connect the D.P.S. red lead to the red/white wire connector.
- 2) Connect the D.P.S. black lead to the black wire connector.
- 3) Turn selector dial to 'TRIGGER/EXT' position.
- 4) Crank the engine and record the reading _____.
- 5) Compare reading to specification _____.
- 6) Is the trigger coil good _____ or bad _____?



Duo300 Electrical & Ignition Systems Diagnostic Procedures

D.P.S. Analyzer Tests to be Performed (Continued)

C. C.D.I. Unit Voltage Test:

WARNING:

Performing this test could cause an uncomfortable shock... Always make sure connections are proper. Do not stand in water when testing any electrical component.

- 1) Connect the red D.P.S. lead to the orange wire.
- 2) Connect the black D.P.S. lead to the black wire.
- 3) Crank the engine record the reading _____.
- 4) Compare to specification _____.
- 5) Is it good _____ or bad _____?

D. Ignition Coil Test

For this test the ohm tester is used. Isolate the coil from the system by disconnecting the black wire and the orange wire from the C.D.I. unit.

- 1) Set the ohm tester to ohm position

Primary resistance test:

- 1) Connect the red tester lead to the orange wire.
- 2) Connect the black tester lead to the coil black wire
- 3) Record the reading _____.
- 4) Compare to specification _____.
- 5) Is the primary test good _____ or bad _____?



Duo300 Electrical & Ignition Systems Diagnostic Procedures

Electrical Component Test Procedures

To simplify troubleshooting, these steps given cover all wire functions. Any malfunctions, such as no operation and erratic readings will be found using these steps.

1) Before beginning any testing of the electrical system, check that the engine has the proper spark plug installed... an incorrect spark plug could cause erratic readings on some electrical gauge readings.

2) Check the battery condition and electrical connections of all components for corrosion, erosion, and loose fasteners. This will affect component specification and functions.

3) Use the ohm meter to make these tests, you may need to isolate the component from the system to make these tests.

4) Always check that no voltage is present before making an ohm test.



Duo300 Electrical & Ignition Systems Diagnostic Procedures

Control Switch Box

The integrated watertight switch box includes the stop, start, and lanyard stop switches. The lanyard stop switch disables ignition and starter motor operation. Therefore, this switch has twin contacts and is connected to both the start and stop switches. ALL switches are installed in the lower casing. This prevents the switches from lost sealing and allows for larger colored buttons.

The wire connector from the switch box contains four wires; green, black, white and yellow/green. This connector plugs into a pig-tale in the main harness that contains a red, black, brown, and white wire coming from the electrical box. When performing test, insert tester leads from the electrical box side.

Start Switch Test

- 1) Turn the tester to the D.C. scale.
- 2) Insert the red test lead into the red wire.
- 3) Insert the black test lead into the black wire.
- 4) Record the voltage reading _____.
- 5) Compare the reading specification _____.
Is voltage present _____?
- 6) Remove the red test lead and insert into the brown wire.
- 7) Press the 'START' button... record the voltage _____.
Is voltage present _____?

NOTE: _____

Due to the starter load when cranking, the voltage will drop to the 10 to 11 volt range. Only crank the engine long enough to obtain a voltage reading.

Should you find the voltage readings are not in specification, you will need to perform a voltage drop test... refer to voltage drop test given in the electrical systems battery service section.



Duo300 Electrical & Ignition Systems Diagnostic Procedures

Control Switch Box (Continued)

To confirm the start switch is working:

- 1) Disconnect the four wire connectors to isolate the switch.

- 2) Connect the ohm tester, using the ohm scale, connect the red tester lead to the yellow/green wire.

- 3) Connect the black tester lead to the black wire.

- 4) Press the 'START' button... the circuit should close. Release the button and the circuit should open. The tester reading should read 'INFINITE'.

- 5) Is the start button in working condition? _____



Duo300 Electrical & Ignition Systems Diagnostic Procedures

Fuel Gauge Test

The fuel gauge contains the control unit that senses the fuel level readings in the tank. The sending unit in the tank contains four floats with magnetic switches. When the fuel level is above the floats, the switch is in the 'CLOSED' position. Each time a switch is opened as the fuel level drops, the fuel gauge will move to the next level one step at a time.

- 1) Connect the D.C. volt meter red test lead to the fuel gauge red wire.

- 2) Connect the black test lead to the fuel gauge black wire.

- 3) Crank the engine and record the voltage reading _____.

- 4) Compare to specification _____.

- 5) Should the gauge receive proper voltage and not function, check the sending unit in the fuel tank.



Duo300 Electrical & Ignition Systems Diagnostic Procedures

Sending Unit Test

- 1) Remove the clamp from the sending unit, and remove the sending unit from the tank.
- 2) Disconnect the wire connector.
- 3) Using the ohm scale, connect the tester leads to the pink wires from the sending unit.
- 4) Hold the sending unit in your hand so that the floats are at a horizontal position.
- 5) Slide the floats to the right side... move each float to the left one at a time and record the reading of each float.

Float 1 _____ Float 2 _____ Float 3 _____ Float 4 _____

All floats should give a reading. Should any float not give a reading, the unit should be replaced.



Duo300 Electrical & Ignition Systems Diagnostic Procedures

Wire Function/Information/Testing Procedures

The following information identifies the wires in the electrical circuits from the electrical box, and their respective functions. Understanding the functions of the system will aid in troubleshooting the test procedures of the system.

- Red wire - supplies the system voltage and is hot at all times.
- Black wire - supplies the ground for all circuits.
- Brown wire - supplies voltage only when cranking the engine.
- Green wire - supplies a small amount of voltage from the lighting coil... approximately 1 to 4 volts at cranking speed and is controlled by the voltage rectifier/regulator.

A. Test Procedure for Main Harness

- 1) Turn the ohm tester to the ohm position.
- 2) Connect the red test lead to the black wire.
- 3) Connect the black test lead to the ground wire post located in the electrical box.
- 4) Record the reading _____.
- 5) Compare to specification; infinite.

B. Voltage Supply when Cranking

- 1) Connect the red tester lead to the brown wire.
- 2) Connect the black tester lead to the black wire.
- 3) Turn the tester to the d.c. scale.
- 4) Crank the engine and record the reading _____.
- 5) Compare the reading to specification, 12 d.c. volts.



Duo300 Electrical & Ignition Systems Diagnostic Procedures

Wire Function/Information/Testing Procedures (Continued)

C. Green Wire Low Voltage from Lighting Coil:

- 1) Connect the red tester lead to the green wire.
- 2) Connect the black tester lead to the black wire.
- 3) Turn the tester to the d.c. volt scale.
- 4) Crank the engine and record the reading _____.
- 5) Compare the reading to specification, 1 to 4 volts.

No voltage output would indicate a charging system problem and would require checking charge coil output test.

D. Engine Over Heat Test

The engine is protected by an over heat sensor in the C.D.I. circuitry. When the sensor detects a temperature in excess of 176½ F. to 80½ C., than the process starts over again until the problem is serviced. The engine will operate normal below 2500 R.P.M. range as long as coolant is present to protect the engine. Should the sensor become corroded or internally shorted, a falser over heat signal might be given to the C.D.I. Unit. In response, the C.D.I. Unit would reduce the engine R.P.M. which would result in reduced performance. Should this happen:

- 1) Test this circuit by unplugging the heat sensor at the wire harness.
- 2) Test run the engine... if performance returns to normal, replace the sensor.

CAUTION:

Do not run the engine for over one to two minutes with the sensor disconnected as engine damage will result.



Duo300 Electrical & Ignition Systems Diagnostic Procedures

Ignition System Overview

The WetJet Duo300 components are designed specifically for marine application... waterproof, maintenance-free capacitor discharge ignition (C.D.I.) system. Even at slow speeds, the T-7 engine C.D.I. provides a strong spark because a higher voltage is developed in the ignition coil secondary. This results in less spark plug fouling. Therefore, operation at low speeds for a long time becomes possible, and the C.D.I. does not require maintenance at regular intervals.

The C.D.I. System features:

Dual-lead Coil - More compact, lighter weight.

Electronic Advance - No mechanical advance linkage or centrifugal governor means less maintenance and greater reliability.

Overheat protection - Also built in the C.D.I. units; cuts off spark at 6050 ± 150 R.P.M. to prevent engine damage from over-revving. This is especially important in a jet-driven boat, because the jet intake can suck in air in rough water, and cavitate (spin with no load).

Spark-resistant electrical box - All electrical components are installed in a spark resistant waterproof box.



Duo300 Electrical & Ignition Systems Diagnostic Procedures

Ignition Components

WetJet C.D.I. system consists of the following components:

Charge Coil - This is the point of origin for the ignition spark output. The charge or source coil produces an alternating current (A.C.) voltage by induction as magnets on the flywheel rotate past the heel of the coil.

C.D.I. Unit - A capacitor in the unit stores the output voltage from the charge coil and releases it when signaled by the pulsar coil. The C.D.I. also controls the ignition spark advance to give peak performance.

Pulsar Coil - The pulsar coil also produces A.C. voltage by induction. Its output is correctly timed to trigger the charge held by the capacitor in the C.D.I. unit giving proper timing for engine load demands.

Ignition Coil - The ignition coil is a transformer that increases the voltage output from the capacitor in the C.D.I. unit. The increase is sufficient to cause spark to jump the gap at the spark plug.

Spark Plug - The spark plug is the final link in the chain of ignition components. It delivers the spark to the combustion chamber where the air-fuel mixture ignites. The spark plug also helps control the engine combustion temperature.

Wires and Connectors - Throughout the ignition system, wires and their connectors are necessary to route the various electrical currents. It is very important to inspect and handle these components carefully when testing.

C.D.I. Unit System Operation:

Magnets attached to the flywheel pass over the charge coil, mounted to the stator plate. As this happens an A.C. voltage is produced in the charge coil.

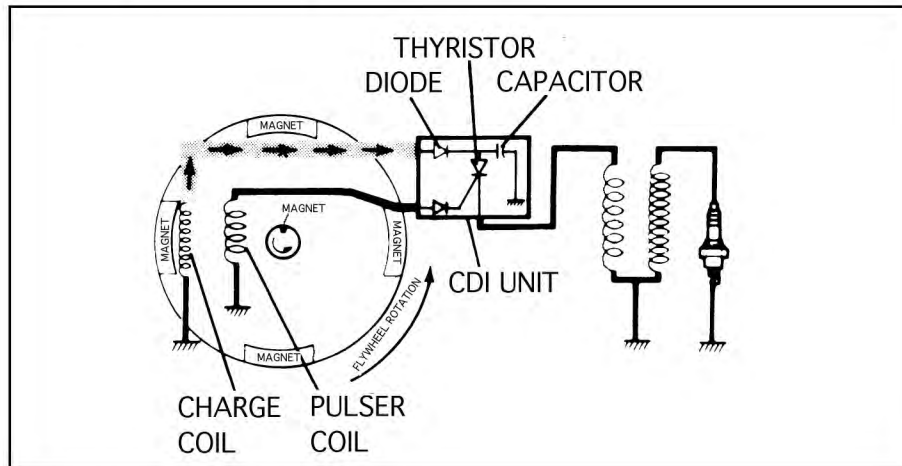

The A.C. voltage is directed to the C.D.I. unit, where a diode converts the A.C. voltage to D.C. voltage. The D.C. voltage charges the capacitor in the C.D.I. unit.

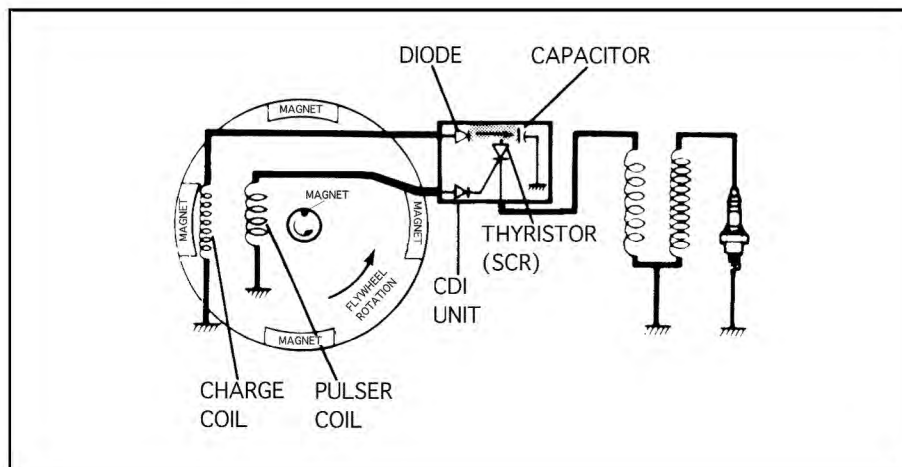

C.D.I. Unit System Operation (Continued)

Also, the C.D.I. Unit contains a thyristor, or called a S.C.R. (silicon-controlled rectifier). The S.C.R. is similar to a diode in that it allows current to flow only in one direction. However, the S.C.R. will not allow any current to flow through it until it receives a sufficiently high voltage at its gate. After the gate has been triggered, the thyristor will not turn off until current flowing from its anode to its cathode stops, even if the current is interrupted. This characteristic allows the thyristor to be used as an electronic switch.

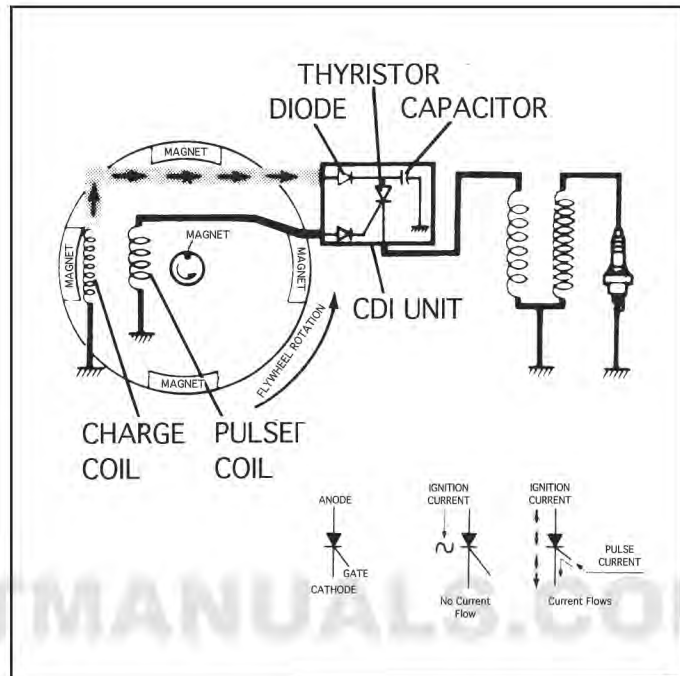

The pulsar coil operates on the same principle as the charge coil. The difference is that its output voltage is much lower than the charge coil, and is much smaller in size. Rather than having a continuous output, it allows output only at certain preset times. The pulsed output occurs when the magnet on the flywheel passes the pulse coil mounted on the stator plate assembly. At this moment, the pulsed current is sent to the thyristor gate. The pulse triggers the gate, and allows the thyristor to operate. When the thyristor begins to pass current, charge is stored in the capacitor, and quickly flows through the thyristor to the primary winding of the ignition coil.

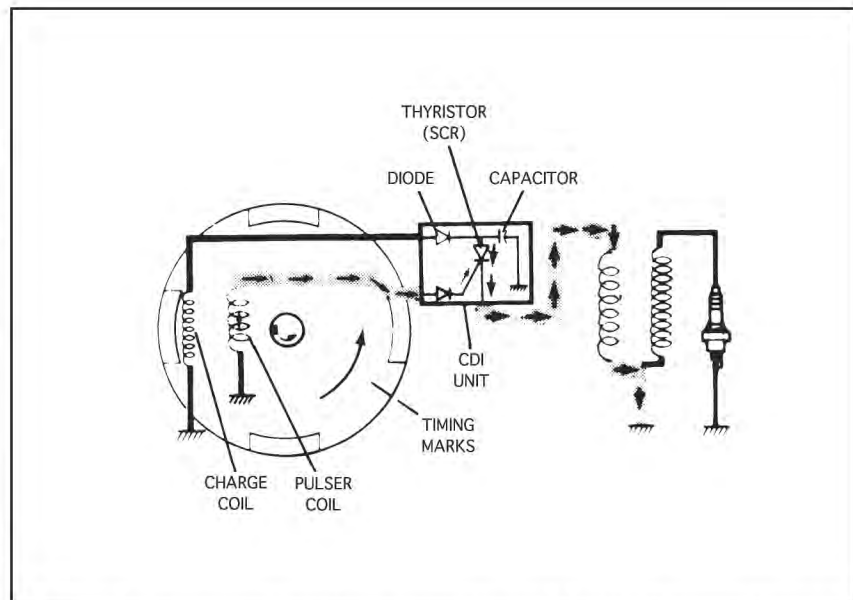

C.D.I. Unit System Operation (Continued)

As the current flows through the primary winding of the ignition coil, a magnetic field is created around the coil. As the magnetic field builds from zero, its lines of magnetic force expand through the coil's secondary winding. This process is called mutual induction. As a result of mutual induction, a very high voltage is developed in the secondary winding and carried through the spark plug wire. This voltage is high enough to cause a spark to jump the electrode gap at the spark plug.

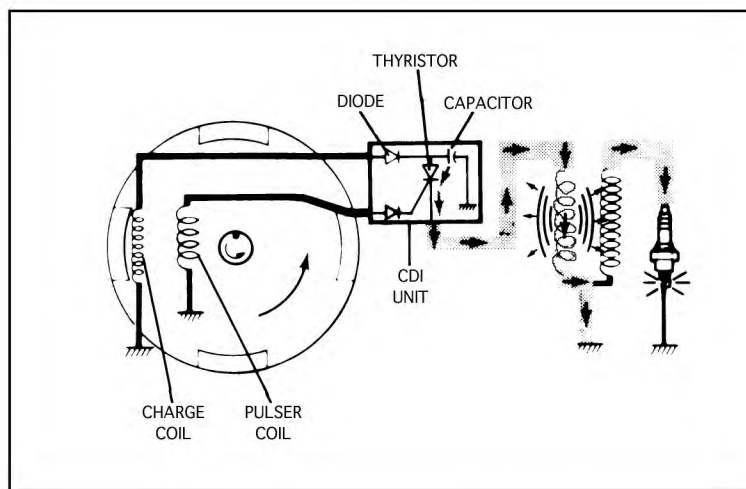

The basic operation of the T-7 C.D.I. system is similar to a conventional C.D.I. system, except with some modifications to include the electronic ignition advance, engine overheat protection, and engine over-rev functions.

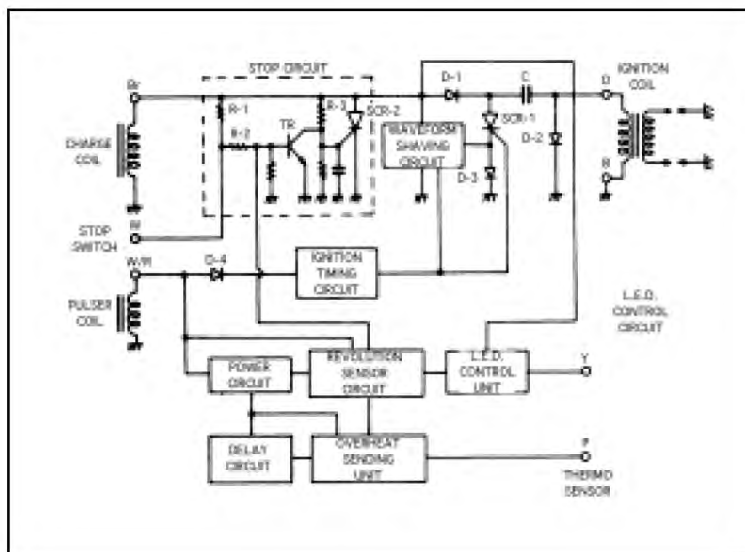



Duo300 Electrical & Ignition Systems Diagnostic Procedures

Component Functions

Let's look at how each of the components function in the T-7 engine ignition system.

- A. The charge coil charges the capacitor in the C.D.I. unit, as in a conventional system, except that the charge coil pulses are timed so they can be used as pulsar outputs to trigger ignition spark up to 2500 R.P.M. In short, the engine runs off the charge coil up to 2500 R.P.M.
- B. The pulsar coil provides the trigger voltage only above 2500 R.P.M. The pulsar coil also charges the power circuit unlike a conventional C.D.I. system. The power circuit A.C. currents rectified to D.C. current and stabilizes this current to be used for the over-rev and overheat circuits.

Ignition up to 2500 R.P.M.

Unlike a conventional C.D.I. system, the charge coil trigger the C.D.I. Unit to provide spark up to 2500 R.P.M. Part of the charge coil output voltage is modified by a wave form-shaving circuit, and output voltage is modified by a wave form shaving circuit, and is used to trigger the thyristor in the C.D.I. unit. When this reshaped voltage is applied, the S.C.R. opens allowing the capacitor to discharge. The current is released to flow to the ignition coil primary winding, than is induced to a higher voltage in the secondary winding, and on to the spark plugs.

Ignition above 2500 R.P.M.:

Once the engine reaches the 2500 R.P.M., the pulsar coil starts to trigger the thyristor of the S.C.R. in the C.D.I. unit. The pulsar coil A.C. current is rectified by the timing circuit, and sent to the thyristor gate. Because the pulsar signal is more advanced than the charge coil signal, the signal from the charge coil has no further effect on the thyristor gate.

Over-Rev:

When the engine speed reached 6050 ± 150 R.P.M., the rev sensor circuit in the C.D.I. unit sends the ignition current to ground. This grounds the charge coil output, until the R.P.M. is reduced by 50 R.P.M. Than, the rev sensor circuit re-opens, allowing normal ignition to occur.



Duo300 Electrical & Ignition Systems Diagnostic Procedures

Component Functions (Continued)

Overheat Condition:

Overheat section is accomplished by the overheat sensor through the overheat circuitry. When the sensor detects a temperature in excess of 176° F. 80° C., the thermosensor located in the cylinder head grounds the circuit. This action causes the rev sensor circuit to ground the charge coil output in the C.D.I. unit. At the same time, a delay circuit in the C.D.I. unit ensures that engine R.P.M. reduction is gradual, not instantaneous. When the engine reaches 2500 to 3000 R.P.M., the rev sensor circuit activates allowing normal spark for an instant until the engine speed increases. Then, the process starts over. This allows normal operation of the unit below 2500 R.P.M. only.

Engine Stop Switch:

Pressing the 'STOP' switch button, or detaching the lanyard from the 'STOP' switch grounds the charge coil output. The C.D.I. unit is not charged, and no spark occurs.

Ignition Coil:

The T-7 engine ignition system uses one ignition coil to fire two spark plugs. In this ignition system, both cylinders fire at the same time. However, being only one cylinder is on its compression stroke at a time, there is no fuel/air mixture in the other cylinder to be compressed when the piston is at the bottom of its stroke. This is also called a wasted spark. In an ignition coil, when voltage passes through the primary winding in one direction, the voltage is induced in the secondary

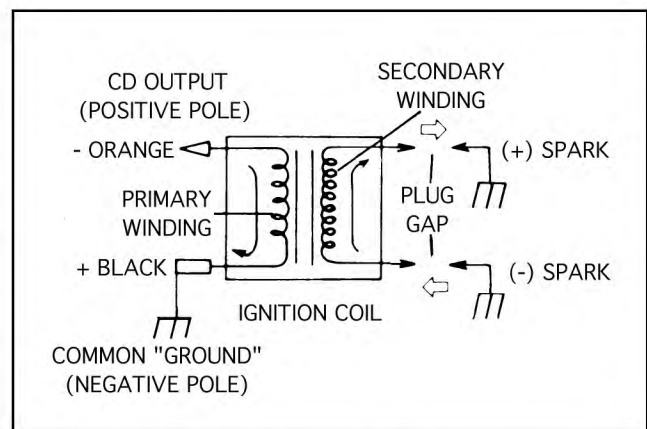

winding and flows only in one direction. The coil fires both spark plugs at the same time; one plug fires from positive to ground, and the other plug fires from negative to positive.

Example: When a spark travels from "ground" to the spark plug center electrode, it's called a negative spark. The same holds true that when a spark travels from the plug center electrode to ground, it is called a positive spark.



Duo300 Electrical & Ignition Systems Diagnostic Procedures

Quiz

1. When the engine is running and the lanyard is disconnected from the stop switch, which of the following occurs?
 - A. Ignition cannot be restarted until the engine comes to a complete stop
 - B. Charge coil is grounded
 - C. 12 volts is applied to the C.D.I. unit
 - D. None of the above.

2. Before testing an electrical problem, what is the first step to be taken?
 - A. Check engine compression
 - B. Check battery condition
 - C. Check loose electrical connections
 - D. Verify complaint

3. Performing electrical tests on the Duo300 using the D.P.S. Analyzer, connecting the test leads can be done with the engine running
 - A. True
 - B. False

4. Which current loop triggers the C.D.I. System?
 - A. Secondary
 - B. Exciter
 - C. Primary
 - D. Pulsar



Duo300 Electrical & Ignition Systems Diagnostic Procedures

Quiz

5. If the ignition system primary circuit shows no voltage at the C.D.I. Unit, the next test would be to:
- A. Test for voltage output of the charge coil
 - B. Do a resistance check of the ignition coil
 - C. Check for shorts and opens in the battery circuit
 - D. Replace the coil
6. The engine is protected by an over heat sensor in the C.D.I. circuit. When the over heat sensor detects an overhead condition. What occurs?
- A. A buzzer goes off
 - B. The ignition will shut off
 - C. The light come on
 - D. The R.P.M. will reduce to 2500 R.P.M.
7. The engine seems to run in good condition, but it only revs up to or about 2500 R.P.M. What circuit would cause this condition?
- A. Voltage regulator/rectifier
 - B. Over-rev sensor
 - C. Over-heat sensor
8. The fuel gauge won't show any reading when the engine is running. What could cause this condition?
- A. Not receiving voltage on the red wire
 - B. Not receiving voltage on the black wire
 - C. Faulty fuel gauge
 - D. Fuel sending unit failure



Duo300 Electrical & Ignition Systems Diagnostic Procedures

Quiz

9. When the lanyard is connected to the engine stop switch, there is a small current draw:
- A. True
 - B. False
10. You have performed all the tests, looked at and performed all if any service bulletins, done everything you could think to make this boat run. You are about to call the Service Department for help. What should you do first?
- A. Repeat the test procedure
 - B. Ask another technician for help
 - C. Write down your test results before calling for help
 - D. Substitute parts from a know good unit

WATERCRAFTMANUALS.COM

Dealership: _____	State: _____
Your Name: _____	
Instructor Name: _____	
Score: _____	Date: _____

Have your instructor check your work. Clean up your workstation for the next student.